

THERMOCOUPLE CALIBRATION FURNACE



Thermocouple Calibration Furnace

Model 9112A

- Combined stability and uniformity better than $\pm 0.4^\circ\text{C}$
- RS-232 serial interface standard
- High capacity for simultaneous comparison calibrations
- CE compliant

Need the most accurate thermocouple calibrations possible? The Hart Model 9112A Thermocouple Furnace gives you a broad temperature range to 1100°C , stability up to $\pm 0.05^\circ\text{C}$, and all at an excellent price. In addition, you can take advantage of optional MET/TEMP II software that completely automates the furnace and calibration processes.

Alternative calibration tools such as a sand bath or fluidized alumina bath have been used for calibrations up to 700°C but with very poor comparative performance. Gradients of several degrees are common in a sand bath, along with poor stability, resulting in low-accuracy calibrations. Sand baths are also known to create a troublesome dust problem. Why buy poor performance and lab pollution?

Calibration furnaces are an excellent alternative to sand baths, especially for thermocouples, RTDs, and optical fiber

probes. With a five-hole standard block and custom blocks available, the 9112A doesn't limit the size and shape of sensors you can calibrate the way other furnaces do. In addition, most calibration furnaces have poor stability.

Automation Software

Hart's 9938 MET/TEMP II software lets you use your PC to automate your calibrations. Not only does the software operate the furnace, it also automates Hart readouts along with the calibration procedures. Read more about our software packages starting on page 74.

Unique Engineering

The 9112A employs a special heater design for temperature uniformity and rapid heat rates. The heaters are embedded in a refractory ceramic-fiber material, forming a two-piece heating assembly. A quartz tube

lines the entire test zone of the furnace, insulating the isothermal block and your work from the high-power heater windings while supporting the block and further equalizing temperature distribution.

The isothermal block assembly is machined from a high-nickel-content alloy for good thermal conductivity and resistance to high-temperature oxidation. The central block is sized for optimum balance between sufficient mass for good stability/uniformity and small enough mass for rapid heating/cooling and stabilization. The assembly makes use of two smaller alloy blocks as thermal barriers and heat sinks. Guide tubes connect the blocks and guide your probes to the heart of the block. A thermal shield at the front of the assembly prevents heat loss at the front of the furnace.

Multiple Probe Calibrations

The standard furnace block accepts up to four probes under test and one reference probe. The four test holes take 1/4-inch-diameter probes, and the reference hole accepts the slightly larger and typical standard type S thermocouple or an SPRT. Custom isothermal blocks can handle a specific number of probes with different diameters and depths. Call our sales department for a custom quote.

Microprocessor Control

A microprocessor-based digital temperature controller makes set-point adjustments fast and easy. Both set and actual temperatures are simultaneously displayed for your convenience. A fast push-button adjustment is used for manual temperature settings. The controller is factory tuned for best performance between 300°C and 1100°C when the tuning function is set for automatic conformity to the set-point requirements. When using the furnace below 300°C , controller adjustments are made to achieve high stability.

The isothermal block design and the controller auto-tuning combine to give you metrology-level performance. The "B" block delivers uniformity of $\pm 0.1^\circ\text{C}$ at the low end and $\pm 0.3^\circ\text{C}$ or better at the high-temperature end.

Range: 300°C to 1100°C

The stability figures quoted in our specification table are for mid-term to long-term stability. Short-term stability during a comparison calibration is even better.

Wide-range and high-temperature calibration work are now easier and more affordable due to Hart's innovative 9112A design. Thermocouples, RTDs, and other sensors are all calibrated with a greater level of confidence and accuracy.

Specifications

Range	300°C to 1100°C (572°F to 2012°F)
Stability	±0.05°C at 300°C ±0.1°C at 700°C ±0.1°C at 1100°C
Uniformity	±0.1°C at 300°C ±0.2°C at 700°C ±0.3°C at 1100°C
Heating Rates	25°C to 900°C: 35 minutes 900°C to 1100°C: 3 hours
Cooling Rates	Nom. at 800°C: ≥300°C/hour Nom. at 600°C: ≥180°C/hour
Stabilization Time	Typically 2 hours midrange, slower at low-temperature end (4 hours), faster at high-temperature end
Interface	RS-232 included on all units
Outside Dimensions	18" H x 14" W x 26" D (457 x 356 x 660 mm)
Thermal Block	16" (406 mm) immersion; includes four wells at 1/4" (6.35 mm) and one well at 0.28" (7.11 mm)
Weight	72.5 pounds (33 kg) with block
Power	230 VAC (±10%), 50/60 Hz, 16 A, 3700 W
Heater	3700 W
NIST-Traceable Calibration	Data at 420°C

Ordering Information

9112A-B Calibration Furnace (includes standard 16" block)



Read about our accredited calibration services on page 156.

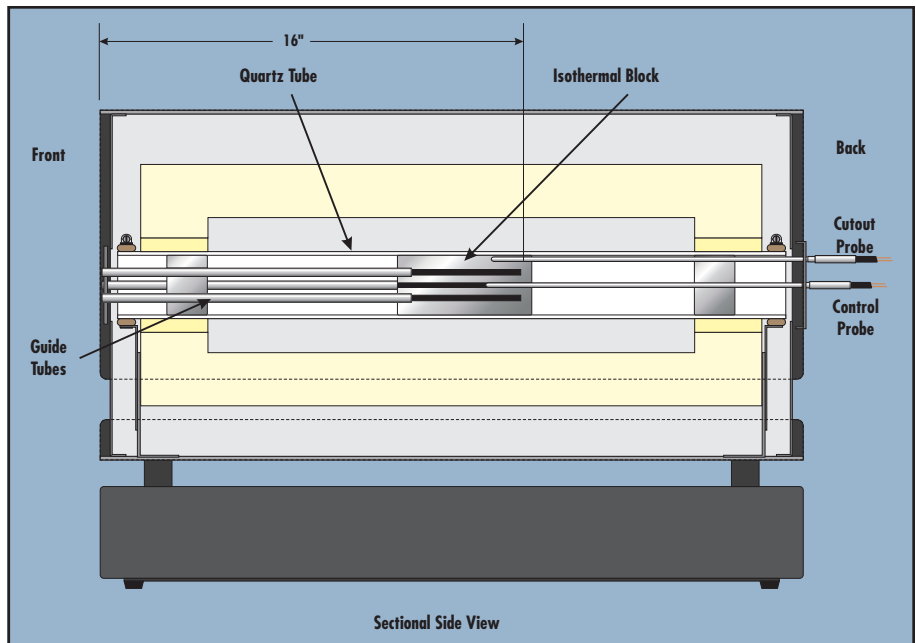

Assistant Scout Master Steve (electro-mechanical engineering) gets the most out of his product designs — and his weekends.

Industrial